



## Power Driver 16 v2

Version 2.0 - July 5, 2017

### **General Description:**

The P-ROC Driver Boards are used to control the activation of connected devices by turning on or off power to the devices in response to commands from a P-ROC. The boards receive commands from the P-ROC over an RS-485 serial bus which allows many boards to be chained together and used simultaneously. There are three different types of Driver Boards that can be used to make up a chain: Master, Power Driver 16, and Power Driver Matrix 8x8.

### **Power Driver 16 Details:**

The Power Driver 16 has two banks of 8 n-channel MOSFETs. Each FET is individually controlled and creates a path to ground when activated. Each bank has a power input header on which it can accept DC power up to 80V. The input power goes through a fuse and is used as a reference for the n-channel FETs. The fused power also goes to a convenience power output header which can be used to supply constant power to one side of the external devices.

The other side of the external devices are connected to the FETs via a keyed 9-pin header. When the FETs are activated in response to commands from the P-ROC, the path to ground is completed, and the devices are activated.

These boards are typically used to control pinball machine features such as coils, motors, flashlamps, individual lamps/leds, etc.

All 16 circuits require an active high signal from the controller (P-ROC, Arduino, etc) to turn on and an active low signal to turn off. Logic on the board itself takes care of driving the transistors properly.

## Connectors:

<b>J1</b>	<b>Logic Power</b>	<b>Required</b>
<b>2-pin Molex: 0.156" spacing</b>		
1	5V	I
2	Ground	I

<b>J9</b>	<b>Serial Data In</b>	<b>Required</b>
<b>3-pin Molex: 0.100" spacing</b>		
1	Serial+	I
2	Serial-	I
3	Ground	I

<b>J10</b>	<b>Serial Data Out</b>	<b>Not Required</b>
<b>3-pin Molex: 0.100" spacing</b>		
1	Serial+	O
2	Serial-	O
3	Groud	O

<b>J5</b>	<b>Bank A High Power In</b>	<b>Required if using Bank A</b>
<b>3-pin Molex: 0.156" spacing</b>		
1	5 to 80V DC	I
2	KEY	N/A
3	Ground	I

<b>J3</b>	<b>Bank A High Power Out</b>	<b>Recommended if using Bank A</b>
<b>3-pin Molex: 0.156" spacing</b>		
1	Fused High Power Out	O
2	Fused High Power Out	O
3	KEY	N/A

<b>J7</b>	<b>Bank A Device Power Inputs</b>	<b>Required if using Bank A</b>
<b>9-pin Molex: 0.156" spacing</b>		
1	Bank A - Data 0	I

2	KEY	N/A
3	Bank A - Data 1	I
4	Bank A - Data 2	I
5	Bank A - Data 3	I
6	Bank A - Data 4	I
7	Bank A - Data 5	I
8	Bank A - Data 6	I
9	Bank A - Data 7	I

<b>J6</b>	<b>Bank B High Power In</b>	<b>Required if using Bank B</b>
<b>3-pin Molex: 0.156" spacing</b>		
1	5 to 80V DC	I
2	KEY	N/A
3	Ground	I

<b>J4</b>	<b>Bank B High Power Out</b>	<b>Recommended if using Bank B</b>
<b>3-pin Molex: 0.156" spacing</b>		
1	Fused High Power Out	O
2	Fused High Power Out	O
3	KEY	N/A

<b>J11</b>	<b>Bank B Device Power Inputs</b>	<b>Required if using Bank B</b>
<b>9-pin Molex: 0.156" spacing</b>		
1	Bank B - Data 0	I
2	Bank B - Data 1	I
3	KEY	N/A
4	Bank B - Data 2	I
5	Bank B - Data 3	I
6	Bank B - Data 4	I
7	Bank B - Data 5	I
8	Bank B - Data 6	I
9	Bank B - Data 7	I

## Addressing:

In order to receive the correct data from the P-ROC, each board's address needs to be set appropriately. The following table describes how to use the dipswitches to set the board address:

Dipswitch	Meaning
1	Address bit 0*
2	Address bit 1*
3	Address bit 2*
4	Address bit 3*

\*On=1, Off=0

When the P-ROC is configured, groups of 8 data bits are assigned to indexes. Bits 3:1 of those indexes should correspond to the desired Driver Board's address, and bit 0 corresponds to the desired bank (0=Bank A, 1=Bank B). The following table illustrates how direct addresses and P-ROC group enable indexes map to the Driver Board addresses and banks:

Driver Board Address / Register Address	P-ROC Driver Group Enable Index	Driver Board Address / Bank
0 / 0	0	0 / A
0 / 1	1	0 / B
1 / 0	2	1 / A
1 / 1	3	1 / B
2 / 0	4	2 / A
2 / 1	5	2 / B
3 / 0	6	3 / A
3 / 1	7	3 / B
4 / 0	8	4 / A
4 / 1	9	4 / B
5 / 0	10	5 / A
5 / 1	11	5 / B
6 / 0	12	6 / A
6 / 1	13	6 / B
7 / 0	14	7 / A
7 / 1	15	7 / B
x / 0	N/A	x / A
x / 1	N/A	x / B

## LEDs:

LED	Meaning
D2	5V
D3	3.3V
D4	Fused Bank A power
D5	Fused Bank B power
D14	Watchdog expired

## Dipswitches:

Switch	Meaning*
1	Address bit 0
2	Address bit 1
3	Address bit 2
4	Address bit 3
5	N/A
6	Watchdog disable
7	N/A
8	Terminate serial bus

\* On=1, Off=0

## Protection:

### Fuses

High Power In goes through a fuse in each bank:

Bank A: F1  
Bank B: F2

It's recommended that users use the High Power Out connectors to supply constant power to the devices being controlled with the board. Bank A devices should get power from J3, and bank B devices should get power from J4. This will help isolate device problems on each bank by hopefully preventing issues on one bank from affect devices on other banks. **Users should make sure to use a fuse with the proper current rating for their application.** If a fuse came installed in the board, it is not guaranteed to be the proper rating for every application.

### Watchdog

Each board has a watchdog circuit that will keep the FETs deactivated when the board is not receiving commands from the Master. This could happen due to a failure in the P-ROC or in the Master, or it could be due to a wiring issue in the serial chain. LED D14 lights up when the FETs are deactivated due to the watchdog timer expiring.

Note - This watchdog functionality is disabled when dipswitch 6 is on.

### Flyback Diodes

Each transistor circuit includes a flyback diode to eliminate voltage spikes on inductive loads, such as coils. It is therefore unnecessary to put diodes on coils activated by this board.

## Serial Chain Termination:

The last board in the physical chain (not necessarily the highest address) needs to be set to terminate the serial chain. This is done by setting dipswitch 8 on.

## PDB Protocol:

The PDB Protocol describes the format of data being received on the Data input pin (J8: pin-1). This is also the format of the serial data sent out on J10.

Serial Bus Protocol (PDB Protocol)	
Bit	Field
Byte 0	{0,0,Board Address[5:0]}
<between bytes>	1-5 IDLE clock cycles
Byte 1	{0,0,0,0,0,Command[2:0]}:  0: Read 1: Write 2: RESERVED 3: RESERVED 4: RESERVED 5: RESERVED 6: RESERVED 7: Clear all registers on board
<between bytes>	1-5 IDLE clock cycles
Byte 2	{0,0,Register Address[5:0]}:  0: Bank A 1: Bank B
<between bytes>	1-5 IDLE clock cycles
Byte 3	{0,0,0,0,Bank data bits[7:4]}
<between bytes>	1-5 IDLE clock cycles
Byte 4	{0,0,0,0,Bank data bits[3:0]}

Each byte is sent MSB first.

A transaction consists of 5 data bytes. There must be at least 10 IDLE cycles between transactions. Between each byte of a transaction there must be between 1 and 5 IDLE cycles.

The data signal must be high during all IDLE cycles.

Data must be sent at 8 MHz, 125ns per bit.

The Bank data bits in Bytes 3 and 4 are all active high. A '1' will turn the corresponding circuit on, and a '0' will turn the corresponding circuit off.

# Example Usage:

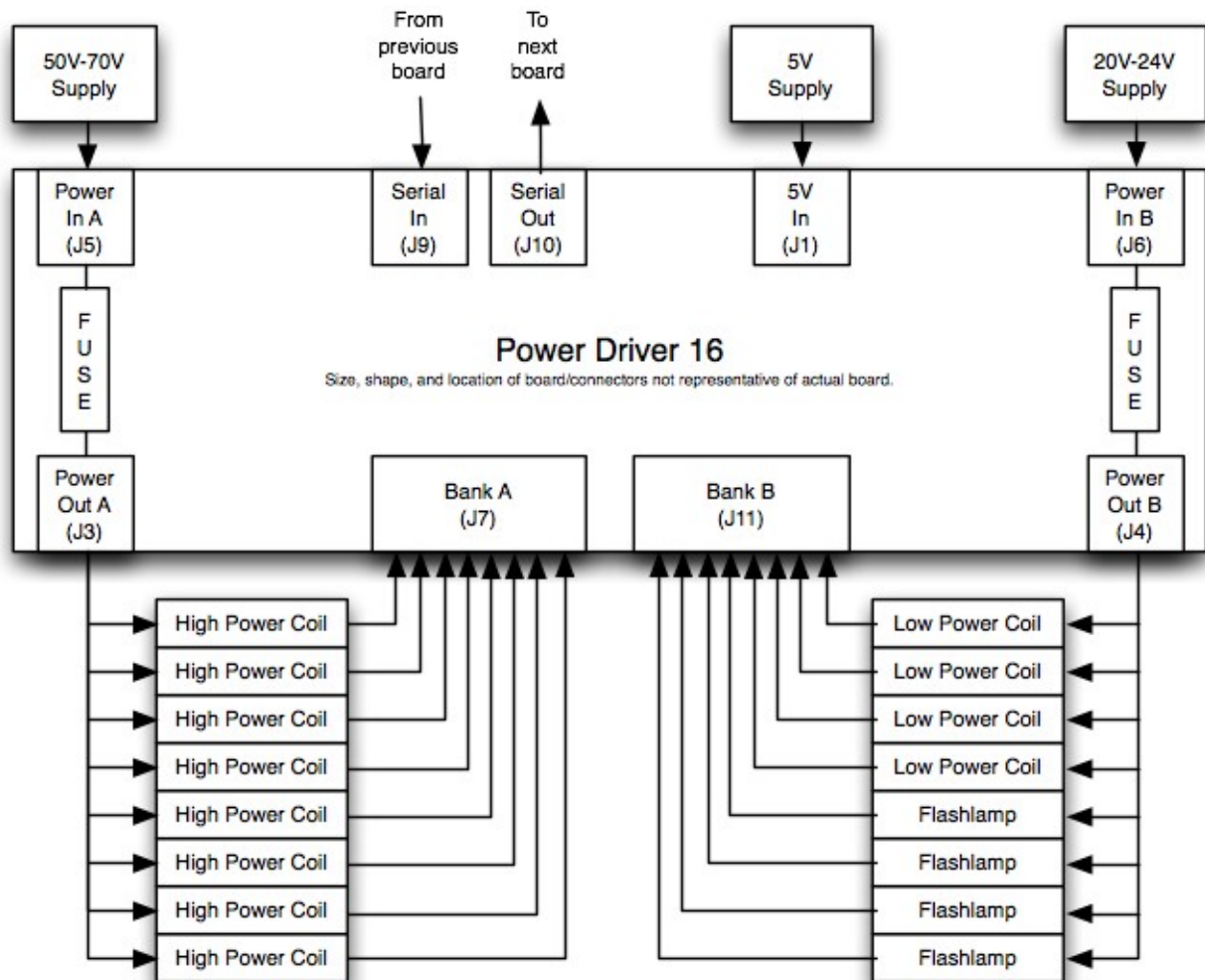



# Getting Started:

## Hardware

- Mount the board using the 4 mounting holes.
- Connect a 5V supply to J1.
- Connect J9 to the previous board in your chain using a 2-wire cable. If the boards are separated by more than a few feet, a shielded & twisted pair is recommended. For short runs, any 2-wire cable should suffice.
- If using Bank A:
  - Connect your power source (5V-80V DC) to J5.
  - Use J3 to supply power to your Bank A devices.
  - Connect your Bank A devices to J7 so the Driver Board can complete the path to ground to activate your devices when commanded.
  - Use an appropriately rated fuse for your application in F1.
- If using Bank B:
  - Connect your power source (5V-80V DC) to J6.
  - Use J4 to supply power to your Bank B devices.
  - Connect your Bank B devices to J11 so the Driver Board can complete the path to ground to activate your devices when commanded.
  - Use an appropriately rated fuse for your application in F2.

## Software

- If using a P-ROC:
  - Once configured, the P-ROC can automatically control a chain of Driver Boards. Configure the P-ROC's Output Controller to use active high polarity, and then set up the P-ROC's Driver Groups as appropriate for your application. For sample configurations and help, visit the PinballControllers.com Driver Board forum at <http://www.pinballcontrollers.com/forum/index.php?board=16.0>.
  - Alternatively, software can control the Driver Board chain directly through the P-ROC by issuing writes to the P-ROC's Serial Bus Output register. Refer to the P-ROC FPGA Specifications for more details.
- If using a microcontroller:
  - Implement the PDB Protocol described earlier in this document. Sample code for the Arduino microcontroller can be found at: <http://www.pinballcontrollers.com/index.php/products/driver-boards/driver-board-faq/83>.